

## How does a Stand-alone system work?

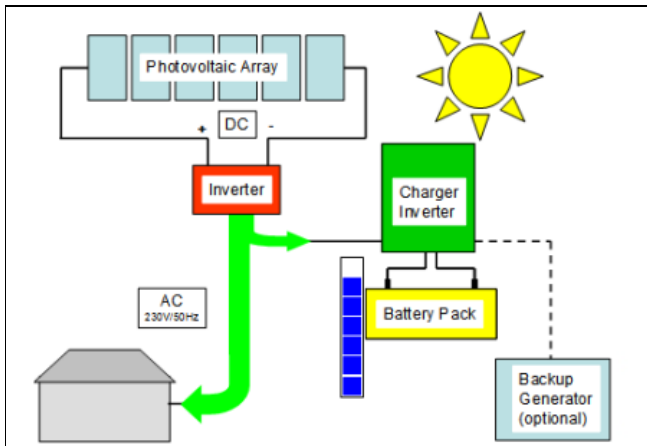

During the day, the production of the SE system is usually **higher** than the consumption in the house.

Any excess electricity is used to charge a large battery pack in order to store the energy.

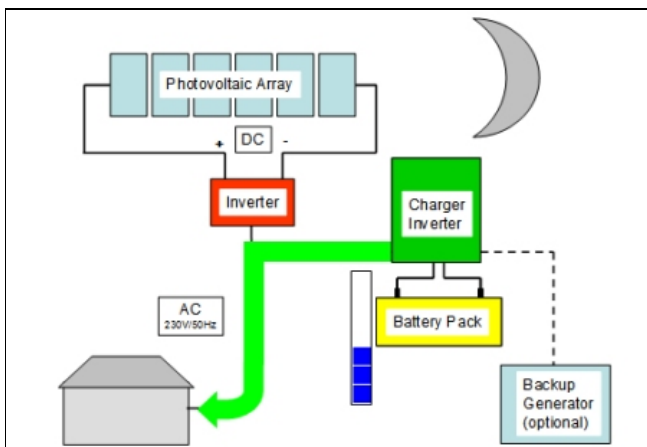

During the night, the SE system produces no electricity.

The required power is taken from the batteries that were charged during the day.

### The system consists of:

- **Photovoltaic Array** (solar panels), usually installed on roof
- **Inverter**, which converts the DC (direct current) to AC (alternating current)
- **Charger Inverter** to control charging of batteries
- **Battery Pack**, sized for the amount of electricity needed for your consumption

### Advantages:

- independence from power company (Grenlec), i.e. also not dependant on oil price
- electricity is always available<sup>1</sup>

### Disadvantages:

- most expensive of all three system types, because of additional devices
- not as environmental friendly, since batteries must be disposed off and replaced after approximately 6-10 years

<sup>1</sup> except in the case of no sunshine for a very long time, which usually doesn't occur in Grenada